

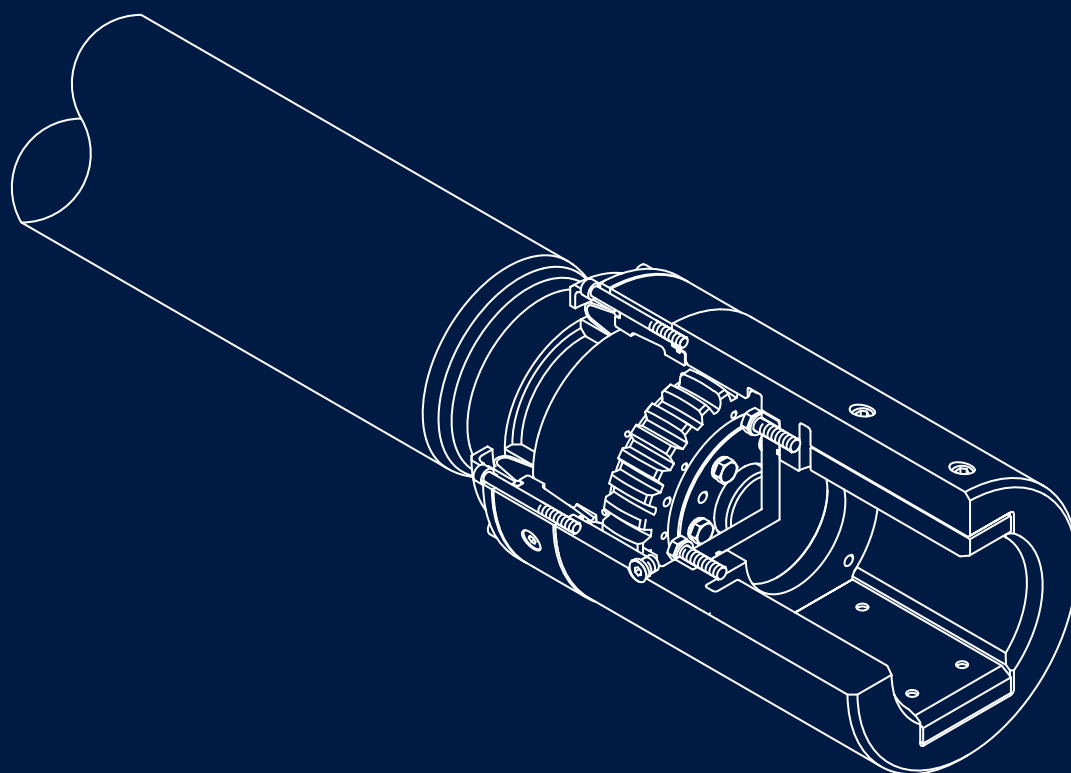

Innovative Power Transmission



**Curved-tooth spindle couplings<sup>®</sup>**  
GS series

## The curved-tooth spindle coupling®

For decades, curved-tooth couplings have proved themselves in practice all over the world. With the curved-tooth spindle coupling®, RENK has taken this technology one step further and developed a shaft connection that is torsionally rigid and yet movable in all directions. The special shape of the curved tooth allows a purely mechanical mobility without any elastic transmission elements, so that the spindle coupling establishes an entirely positive connection.

Thanks to this mobility in all directions, the curved-tooth spindle coupling® is able to compensate axial, angular and parallel shaft misalignments without any loss of the load-bearing capacity of the teeth flanks, which results in its exceptionally high performance. In order to achieve the smallest tip circle possible at a compact and solid tooth, RENK always uses Fellows Stub teeth for spindle couplings.

Curved-tooth spindle couplings® are primarily used whenever high torques must be transmitted at the smallest outside diameter while at the same time, larger misalignments have to be compensated. This applies especially to hot and cold rolling mills, continuous casting installations, straightening presses and rotary kilns.

With its wide range of possible spindle coupling head designs, this driving link is not only the perfect choice for original equipment manufacturers but also ideal for conversions or upgrades of existing facilities.

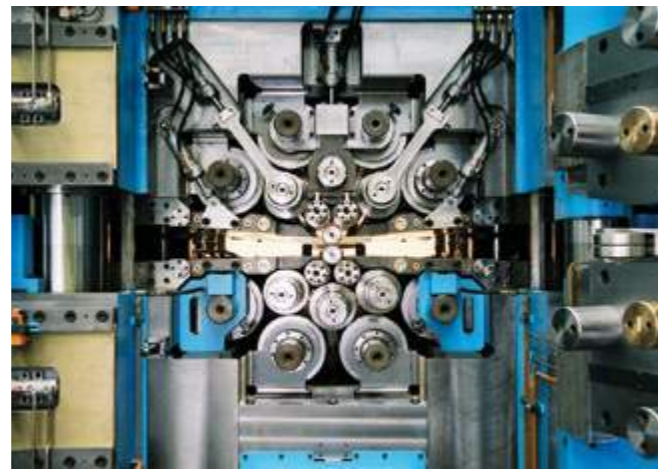

20 roll stand

Source: SMS

In addition to the sizes listed in this brochure, curved-tooth spindle couplings® can be custom built to size 800. The technical data listed in the tables below and the designs shown in the drawings should only be seen as a guideline.

The optimum design for the specific application can be provided by adapting the geometric dimensions, selecting a different kind of sealing or choosing other materials.

Other options include a modification of the tooth system, the use of other hardening methods or the selection of different lubricants. All of these factors can have a significant influence on the final design of the individual curved-tooth spindle coupling®, which is always rated, calculated and built to the customer's specifications.

With decades of experience and the close collaboration between our design, development and sales departments, we are able to offer you almost any special solution conceivable. Some design examples can be found on the following pages.

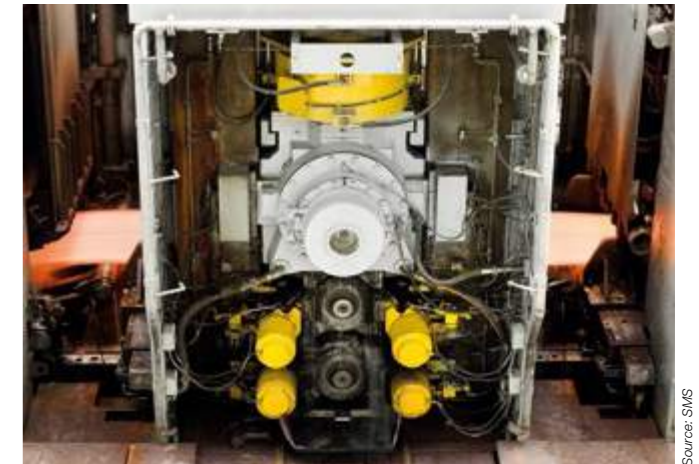

Hot strip mill

Source: SMS



Curved-tooth coupling LBLKT 225, coiler drive in cold rolling mill

Source: Sunrdwig



Curved-tooth spindle coupling®  
GS 320/435,  
for use in hot rolling mill

## Design and construction

Design and construction of each curved-tooth spindle coupling® are tailored to the specific requirements, based on rating using advanced technologies such as the Finite Element Method (FEM).

All curved-tooth spindle couplings® are made of hardened and tempered steel alloys with high yield strengths. The curved teeth of the hubs and the internal toothing are hardened and therefore highly resistant to wear. Also the axially loaded thrust plates and the thrust buttons in the spindle coupling heads are hardened.

The typical meshing behavior of curved teeth in combination with the straight internal toothing results in an exceptionally favorable load-bearing performance which is maintained even at maximum shaft misalignments. Since the points of contact of the tooth flanks

are always near the tooth center, the applied torque is always transmitted by a large number of teeth. This not only reduces the loading of the individual tooth, it also ensures a very smooth rotary motion. Especially in rolling mill applications, this has beneficial effects on the quality of the rolled products. A load dependent self-centering – a combination of tooth tip/tooth flank centering – contributes to the excellent running behavior, particularly at higher speeds.

For today's operators, high availability and a simple and fast replacement of key components are important factors. Moreover, a high degree of standardization of conversion parts offers the advantage of low inventory carrying cost.

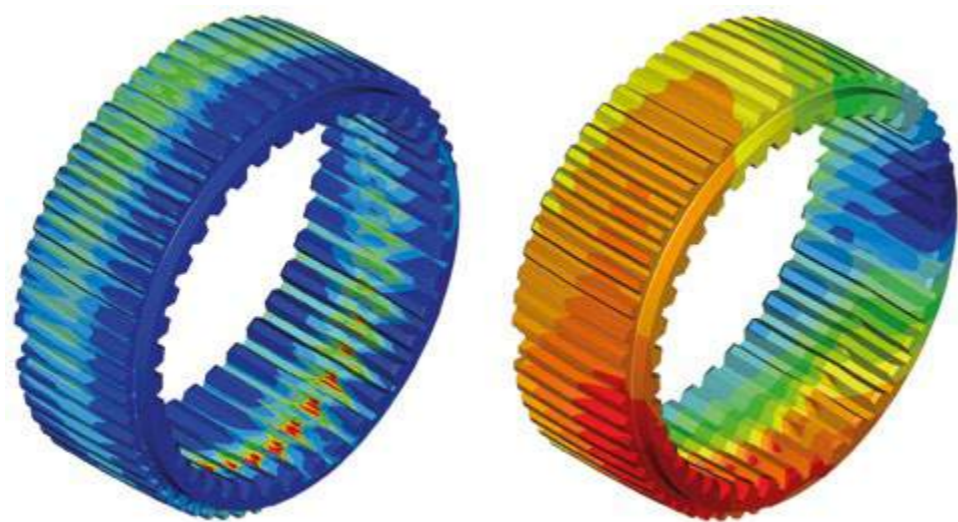

Tensions (left) and deformations of an annular gear

## Lubrication and sealing

Curved-tooth spindle couplings® can be lubricated with oil or with grease, allowing a flexible response to the specific requirements of the plant operator. The type of lubrication has a direct impact on the design of the spindle coupling.

For oil lubrication, we recommend sealing the spindle coupling with a rubber diaphragm. That diaphragm not only prevents oil from leaking out but also foreign matter or rolling emulsion from entering.

For grease lubrication, usually a slide ring with an O-ring seal is selected. The slide ring permits larger misalignments thanks to its radial mobility and thus reduces the churning work inside the O-ring. The selected location of the filler necks ensures that the lubricant can be easily introduced in every operating position.

Curved-tooth spindle couplings® can be lubricated with oil or with grease, allowing a flexible resp transmit highest torques in the most demanding environments. Therefore, the selection of the best suited lubricant deserves special attention. The use of the right lubricant can significantly extend the useful life of the spindle coupling.

A general preselection of the lubricant can be made on the basis of the list of recommended lubricants that is attached to all operating manuals. RENK will be pleased to help plant operators select the lubricant that is optimally suited for the specific requirements.



Curved-tooth spindle coupling® GD 750/850, oil-lubricated, for use in hot rolling mill

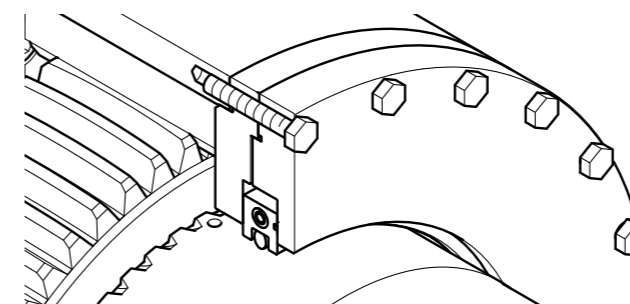

Slide-ring seal for grease lubrication

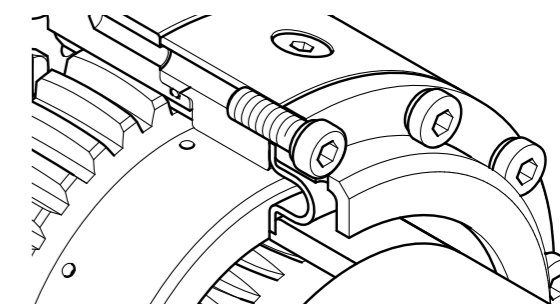

Diaphragm seal for oil lubrication



# Selection and determining the size

Considering all application factors, the nominal coupling torque must be higher than the nominal plant torque. The nominal coupling torque  $T_{KN}$  therefore must be:

$$T_{KN} \geq T_N \cdot K_1 \cdot K_W$$

with

$T_N$  = nominal plant torque [Nm]

$K_1$  = service factor according to Table 1

$K_W$  = alternating load factor according to Table 2

Service factor $K_1$	
Cold rolling mill	1.5 – 1.75
Hot rolling mill	2.25 – 2.75

Table 1: Service factor  $K_1$

The vibratory torques and/or alternating directions of rotation are accounted for by the alternating load factor ( $K_W$ ).

Alternating load factor $K_W$	
One direction of rotation	1.0
reversierender Betrieb	1.3

Table 2: Alternating load factor  $K_W$

If known, also the peak torques or a possible short-circuit torque should be considered for the selection of the coupling.

Peak coupling torque ( $T_{KP}$ ) (for  $10^5$  changes of load)

$$T_{KP} = 1,5 \cdot T_{KN}$$

Maximum coupling torque ( $T_{Kmax}$ ) (for  $10^3$  changes of load)

$$T_{Kmax} = 3 \cdot T_{KN}$$

### Additional information

The technical data in the tables of dimensions are based on an assumed misalignment of 1.5 degrees in operation and 3 degrees in standstill. The figures in the list of dimensions are valid for service temperatures from  $-20\text{ °C}$  to  $+100\text{ °C}$ .

For larger misalignments and/or other service temperatures, please contact RENK AG, Rheine plant.

# GS series with diaphragm seal for oil lubrication

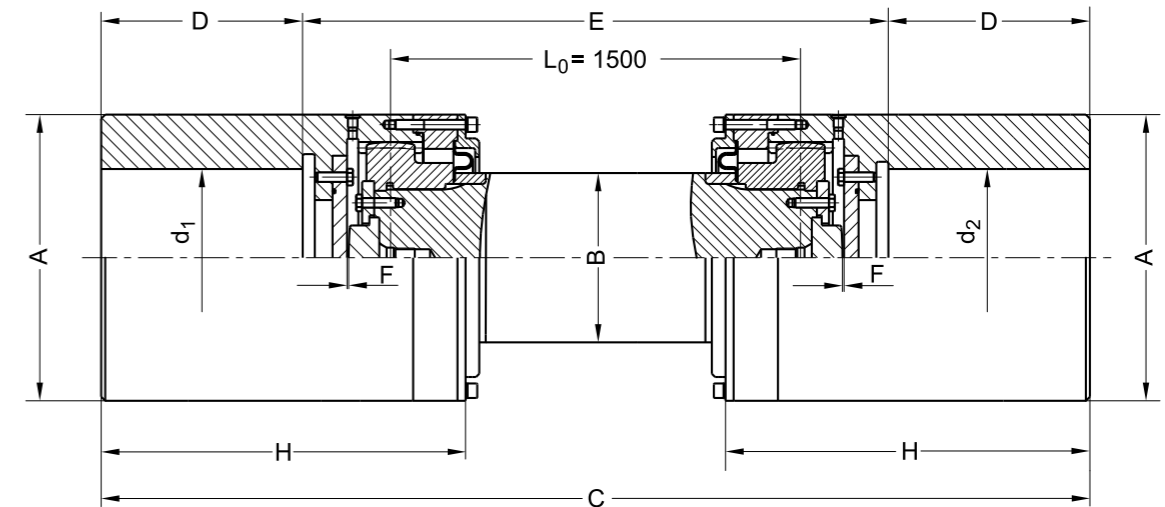

Size	Nominal torque $T_{KN}$ kNm	$d_1, d_2$ max mm	Dimensions							Total oil quantity l	Moment of inertia <sup>1)</sup> kgm <sup>2</sup>	Weight kg
			A mm	B mm	C mm	D mm	E mm	F mm	H mm			
160	14,95	100	160	100	1899	112	1675	2	275	0,60	0,344	147
180	26,0	110	180	115	1925	125	1675	2	288	0,60	0,580	194
200	29,9	125	200	120	1965	140	1685	2	308	0,80	0,872	231
225	53,3	140	225	140	2005	160	1685	2	333	1,00	1,542	312
250	67,6	160	250	150	2055	180	1695	2	358	1,30	2,373	382
280	101,4	180	280	170	2100	200	1700	2	393	1,40	3,992	500
315	136,5	200	315	200	2154	225	1704	2	414	1,30	7,082	690
355	162,5	220	355	210	2218	250	1718	2	452	1,80	11,67	869
395	299,0	250	395	250	2288	280	1728	2	492	2,80	19,84	1175
420	383,5	265	420	270	2308	290	1728	2	502	3,20	26,15	1360
450	490	280	450	290	2358	315	1728	2	537	3,00	36,36	1617
480	560	300	480	310	2408	340	1728	2	572	4,50	49,65	1908
535	800	340	535	350	2502	380	1742	2	619	6,00	81,43	2467
550	950	360	550	370	2522	390	1742	2	629	6,20	92,57	2643
575	1.079	360	575	370	2710	400	1910	2	745	10,20	123,6	3147
605	1.300	380	605	385	2760	425	1910	2	770	10,40	156,9	3581
635	1.560	400	635	405	2810	450	1910	2	795	11,30	194,9	4000
665	1.820	420	665	425	2860	475	1910	2	820	10,10	238,8	4443
695	2.000	440	695	475	2910	500	1910	2	868	12,50	311,6	5264

Angular misalignment during operation  $\pm 1.5$  degrees, in standstill max. 3 degrees.

<sup>1)</sup> Weight and moment of inertia are based on the dimension  $L_0 = 1,500$  mm

## Design examples

Curved-tooth spindle couplings® are tailored to the requirements of your plant. Apart from the various shaft connections and roll connections with flat journals or splines, a number of additional components are available.

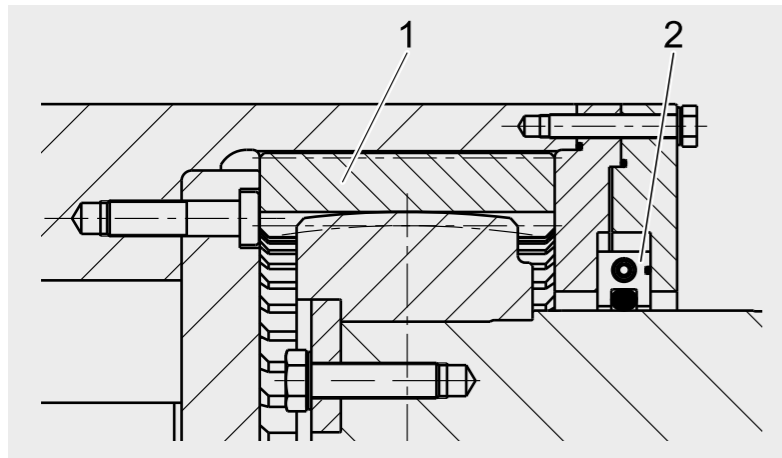

Version with hardened, replaceable angular gears (1) and a slide-ring seal (2) for grease lubrication

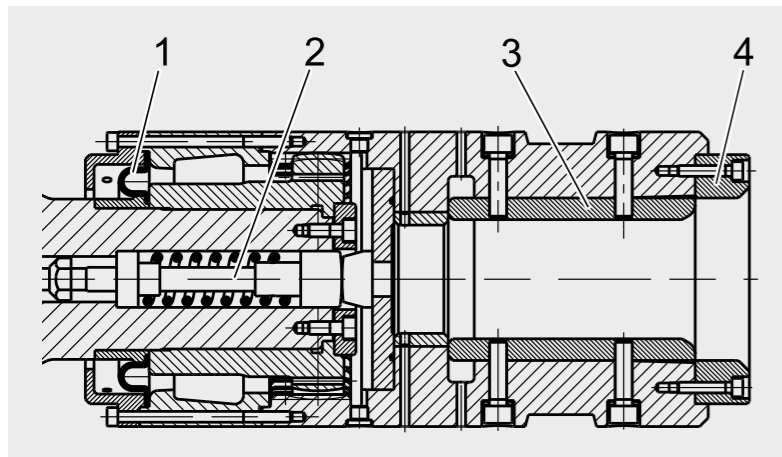

Version with diaphragm seal (1), straightener (2), replaceable hardened steel jaws (3) and centering ring (4)

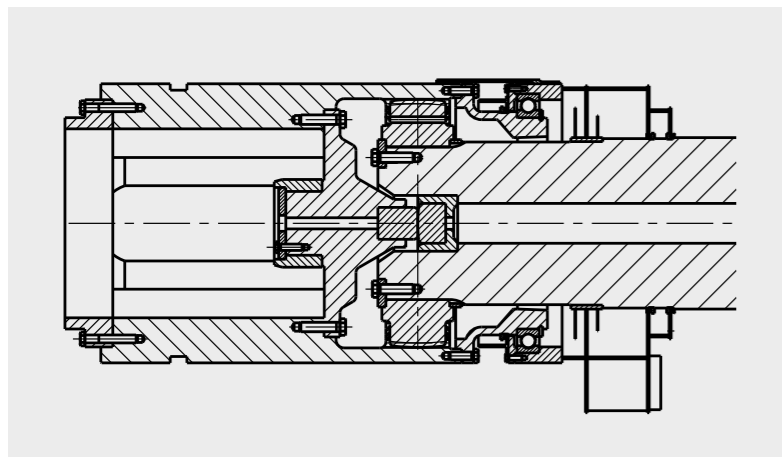

Version made of special case-hardened material for oil flow lubrication

## Flat journal profiles of the roll-side wobblers

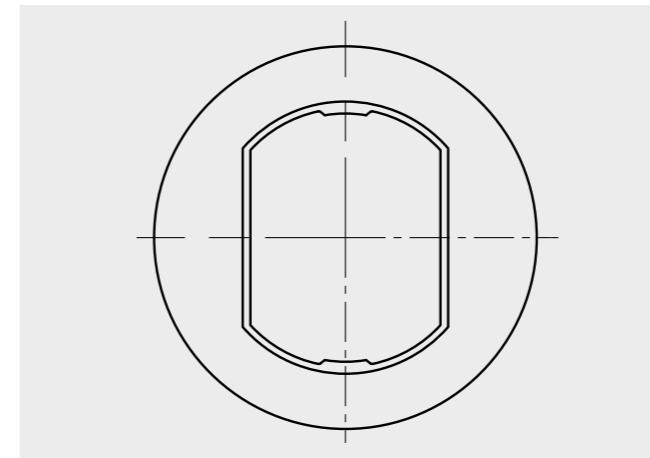

Flat journal profile produced by slotting, preferably used in bores that are large in relation to the outside diameter of the sleeve; exact guidance of the roll journal thanks to centering cams projecting into the inside diameter; optional nitrogen case hardening of the bore to increase the surface strength and wear resistance

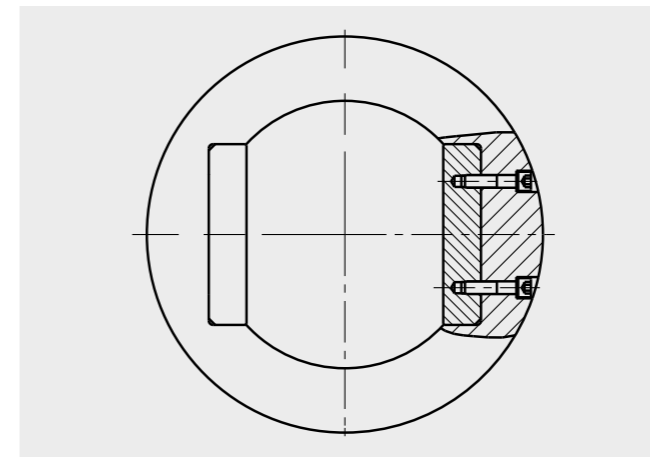

Flat journal profile with inserted hardened and ground steel jaws; high wear resistance against shock torque loads and damage of the coupling sleeve when changing the roll; steel jaws easily replaceable when required; low spare parts inventory carrying cost

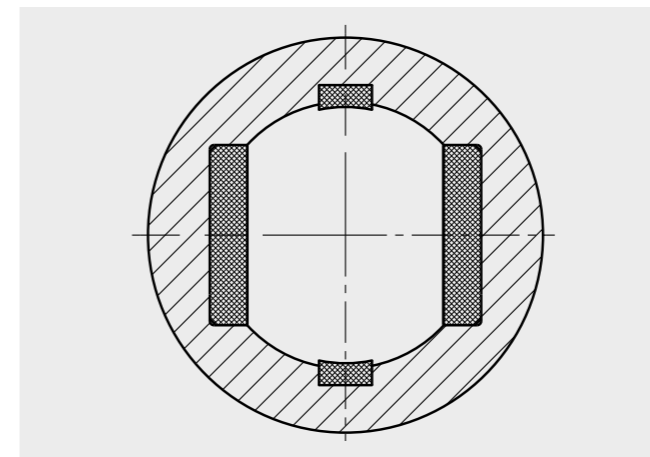

Flat journal profile with inserted jaws and guiding profiles made of hard plastic; high protection against fretting rust when aggressive coolants are used; low inventory carrying cost because only the plastic parts have to be kept available; simple replacement of wearing parts

Other receptacles for the roll journals, e.g. gearing according to DIN 5480, multiple spline profiles or cloverleaf profiles are also possible.

## Curved-tooth spindle coupling® with HYGUARD® safety coupling

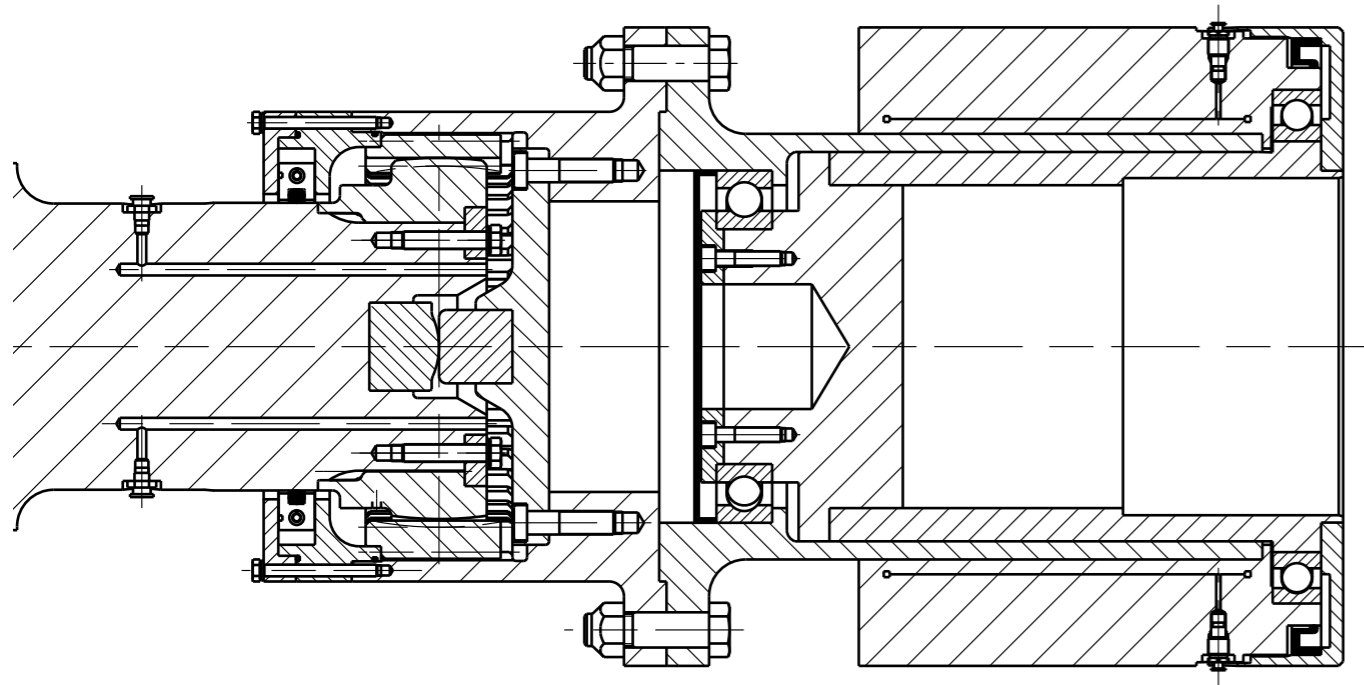

Spindle coupling with HYGUARD® safety coupling

Overload protection devices in the drives of machinery primarily serve to protect valuable assets against damage due to unexpected overloads. Despite continuous modernization and technical advances in mechanical equipment, the risk of such damage has increased rather than decreased.

This can be explained by the rising competitive pressure exerted on the manufacturers who are forced to continuously optimize their equipment. Oversizing key components, which used to be common practice, is hardly applied any more. Modern calculation processes offer all opportunities to design key components in a way that they are continuously safe – despite the trend to lightweight construction.

Nevertheless, machine failures as a result of sudden unforeseeable overloads cannot be fully excluded, and a single damage may be much more expensive than the investment in an effective overload protection.

So appropriate safety devices are still required to protect the machinery. For drive systems, this primarily concerns safety couplings that are meanwhile available in a wide variety of designs. Yet, not all of these couplings are equally suited for every drive. For selecting the right coupling all of the factors that can result in a disruption of the operating process must be considered.

Because of their heavy-duty drives, rolling mills make especially high demands on torque limiting couplings. In case of an overload or a sudden blockage of the roll, the coupling will disengage immediately. This way, it avoids damage to the pinion stand that would otherwise be caused by the high moment of inertia of the drive motor.

The combination of the HYGUARD® system with the proven curved-tooth spindle coupling® acts like a safety coupling with torque limiter. The disengagement torque can be adjusted and remains constant over the entire service period – a reliable protection for valuable machinery and equipment.

Curved-tooth spindle couplings® in combination with a HYGUARD® safety coupling offer the following advantages:

- overload protection with adjustable limitation of the torque
- simple and fast re-starting after disengagement
- constant disengagement torque
- no interruption of the operation as a result of material fatigue
- low costs of downtime
- no costly stock keeping of spare parts.

Upon request, we shall gladly send you our HYGUARD® brochure with further details.



HYGUARD® safety coupling type HDW 300 with torque measurement system in a cold rolling mill after years of service



Curved-tooth coupling  
type SBLk 80 with BWL 70



**RENK Aktiengesellschaft**

**Rheine Plant**

Rodder Damm 170

48432 Rheine, Germany

Phone: +49 5971 790-0

Fax: +49 5971 790-208

Email: [info.rheine@renk.biz](mailto:info.rheine@renk.biz)

[www.renk.eu](http://www.renk.eu)

**A company of the MAN Group**